



Distribuito in ITALIA da
Li StarFish S.r.l.
 Via Cavour, 35
 20063 Cernusco S/N (MI)
 telefono 02-92150794
 fax 02-92157285
 info@listarfish.it
 www.listarfish.it



Disposable Hemocytometer

System Neubauer Improved

DHC-N01

NanoEnTek Inc.

Website : www.nanoentek.com
 E-mail : sales@nanoentek.com

Manufactured by
 NanoEnTek Inc. (HQ)
 12F, 5, Digital-ro 26-gil, Guro-gu, Seoul, 152-740, Korea
 Tel : +82-2-6220-7940 / Fax : +82-2-6220-7721

NanoEnTek USA Inc.
 5627 Stoneridge Drive Suite 304, Pleasanton, CA 94588
 Tel : 925-225-0108, 888-988-0108 (Toll free) / Fax : 925-225-0109

Manufacturing site
 NanoEnTek Inc. (Hwaseong)
 851-14, Seohae-ro, Paltan-myeon, Hwaseong-si, Gyeonggi-do,
 445-917, Korea

EC REP

MT Promedt Consulting GmbH
 Altenhofstrasse, 80, 66386 St. Ingbert, Germany

All the materials in this manual are protected by Korean and international copyright laws. This manual may not be reproduced, translated, published or distributed by any means without the permission of the copyright owner.

The information in this manual is described as correctly as possible, but may be changed without prior consent or notification.

Documentation : NESMU-DHC-001E (V.0.2)

Copyright 2013, by NanoEnTek Inc.
 All rights reserved. Published in Korea.

Unpacking

When you receive the C-Chip (DHC-N01) for the first time, you will find the following components in your package.

Disposable hemocytometer
 Instruction manual

Safety Precautions

For analyzing hazardous or potential infectious materials:

- Take necessary precautions
- Handle with care
- Dispose in an appropriate way

Long exposure to solvents will cause the slide to warp. Xylene and toluene based mounting media should be avoided. Glycerol, gelatin, and other aqueous-based media are recommended.

Safety Symbols

The safety symbols on the C-Chip (DHC-N01) are intended to inform you of potential danger or a particular caution. Before use, please read and the consult the guide for the symbols and their meanings.

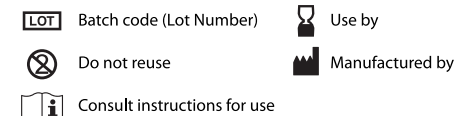

NOTE: The C-Chip (DHC-N01) is for **single use** only. **Do not reuse.** It should be used immediately after unsealing. The warranty on the C-Chip included in the conditions of supply is valid for 24 months from the date of manufacturing. The **expiration date** is indicated on the front side of outer box.

Introduction

The C-Chip (DHC-N01) is a disposable plastic hemocytometer used for manual cell counting. It consists of surface-patterned two enclosed chambers with two ports for sample injection (Fig. 2).

The DHC-N01 grid pattern is exactly same as the Neubauer Improved. It consists of 9 large squares, each measuring 1 x 1 mm, and the depth of the chamber is 0.1 mm. Each square has a total volume of 0.1 mm³ or 10⁻⁴ cm³ (Fig. 1).

The central square is divided into 25 small squares with triple lines and four corner squares are divided into 16 small squares.

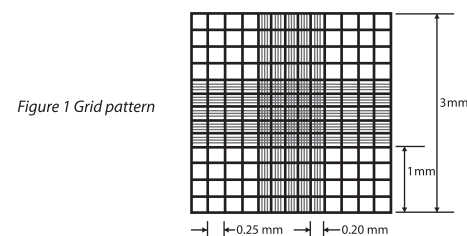

Figure 1 Grid pattern

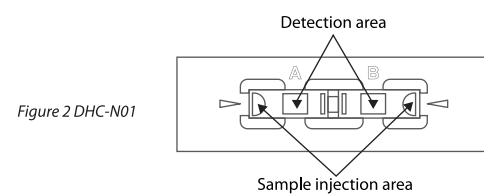

Figure 2 DHC-N01

Counting with C-Chip

A. General Methods

1. Mix the samples well.
2. Load 10 μL of sample into the sample injection area in Fig. 2, so that it fills the chamber by capillary action.
3. Count the cells under the microscope.

$$\text{Cells per mL} = \text{average count per square} \times \text{dilution factor} \times \text{volume factor}$$

B. Mammalian cell counting

1. Treat the cell samples with trypsin-EDTA.
2. Carefully remove the supernatant with a pipette tip without disturbing the pellet.
3. Add an appropriate volume of growth media or PBS to dilute to a final concentration of 5 x 10³ cells/mL to 5 x 10⁶ cells/mL.
4. Thoroughly re-suspend the cell pellet with a pipette
5. Check visually if there are any cell clumps or agglomerates.
6. Load 10 μL of sample into the sample injection area in Fig. 2.
7. Count the cells in 5 large squares.

$$\text{Cells per mL} = \frac{\text{cells in 5 large squares}}{5} \times \text{dilution factor} \times 10^4 \text{ (volume factor)}$$

C. Erythrocyte counting (1:200 dilution)

1. Dilute blood using accepted laboratory methods.
2. Load 10 μL of diluted sample into the sample injection area in Fig. 2.
3. Count the erythrocytes in the 5 small squares (four small corner squares and one small middle square) of the large center square.

$$\text{RBCs per mL} = \frac{\text{cells in 5 corner squares} \times 5 \times 200 \text{ (dilution factor)} \times 10^4 \text{ (volume factor)}}{5}$$

D. Leukocyte counting (1:20 dilution)

1. Dilute blood using accepted laboratory methods.
2. Load 10 μL of diluted sample into the sample injection area in Fig. 2.
3. Count the leukocytes in the 4 large corner squares.

$$\text{WBCs per mL} = \frac{\text{cells in 4 corner squares}}{4} \times 20 \text{ (dilution factor)} \times 10^4 \text{ (volume factor)}$$

Trouble shooting

In case of poor visibility results,

Carefully load samples into the C-Chip in order to prevent the introduction of **air bubbles**. Observe after removing the dust from samples. Adjust the focus of the microscope.

C-Chip

INSTRUCTIONS

Grid pattern of Bürker
DHC-B01

Grid pattern of Bürker-Türk
DHC-B02

Grid pattern of Fuchs-Rosenthal
DHC-F01

Grid pattern of Malassez
DHC-M01



Grid pattern of Bürker **DHC-B01**

The C-Chip (DHC-B01) grid pattern is exactly same as the Bürker. It consists of 9 large squares, each measuring 1 x 1 mm, and the depth of the chamber is 0.1 mm. Each square has a total volume of 0.1 mm³ or 10⁻⁴ cm³.

The large squares are subdivided into 16 group squares with 0.2 mm sides. The group squares correspond in size to the Neubauer grid, but have no further subdivisions.

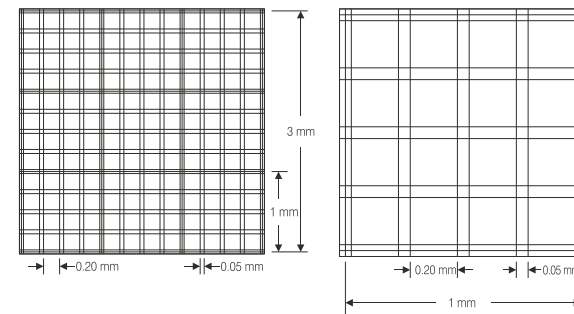

Grid pattern of DHC-B01

Grid pattern of Bürker-Türk **DHC-B02**

The C-Chip (DHC-B02) grid pattern is exactly same as the Bürker-Türk. It consists of 9 large squares, each measuring 1 x 1 mm and the depth of the chamber is 0.1 mm. Each square has a total volume of 0.1 mm³ or 10⁻⁴ cm³.

The large squares are subdivided into 16 group squares with 0.2 mm sides. In the central large square, each group is subdivided into 16 mini squares with 0.05 mm sides (= 0.0025 mm²).

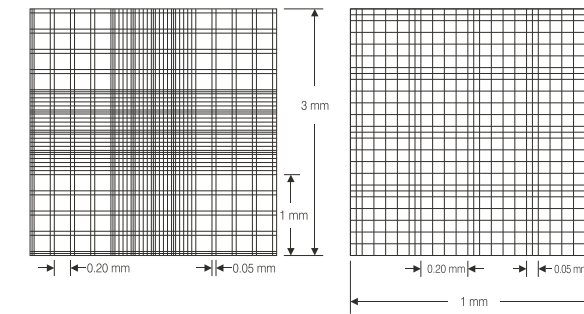

Grid pattern of DHC-B02

Grid pattern of Fuchs-Rosenthal **DHC-F01**

The C-Chip (DHC-F01) grid pattern is exactly the same as the Fuchs-Rosenthal. It consists of 16 large squares orientated by triple lines, each measuring 1 x 1 mm, giving a total area 4 x 4 mm.

The depth of each chamber is 0.2 mm, giving a on large square with triple line has a volume of 0.2 µL, total volume for counting area of 3.2 µL (3.2 mm³).

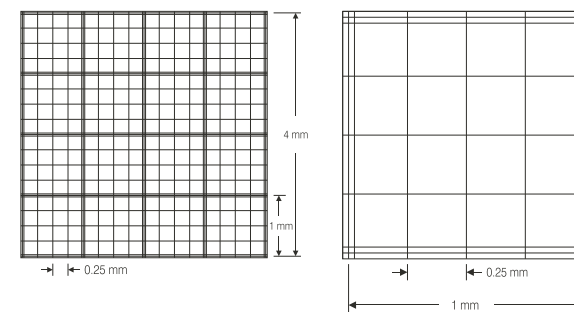

Grid pattern of DHC-F01

Grid pattern of Malassez **DHC-M01**

The C-Chip (DHC-M01) grid pattern is exactly same as the Malassez. It consists of 25 large squares, each measuring 0.2 x 0.25 mm and the depth of the chamber is 0.2 mm. Each square has a total volume of 0.01 mm³ or 10⁻⁵ cm³.

The large squares are subdivided into 20 small squares with an area of 0.0025 mm².

Cells per mL =
average count per large square x dilution factor x 10⁵ (dilution factor)

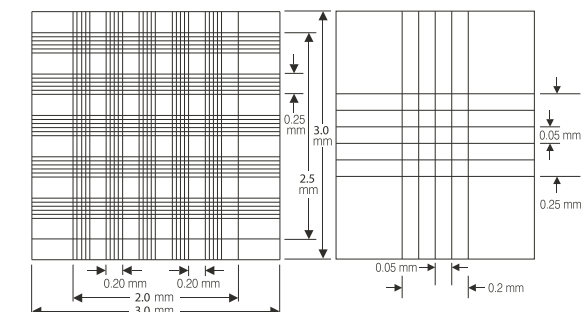

Grid pattern of DHC-M01